

SERIE SERIES 1	ES611AM3TG	12 V C.C.
SERIE SERIES 1	ES621AM3TG	24 V C.C.
SERIE SERIES 2	ES612AM3TG	12 V C.C.
SERIE SERIES 2	ES622AM3TG	24 V C.C.
SERIE SERIES 3	ES613AM3TG	12 V C.C.
SERIE SERIES 3	ES623AM3TG	24 V C.C.

Fili Cables L = 200 mm

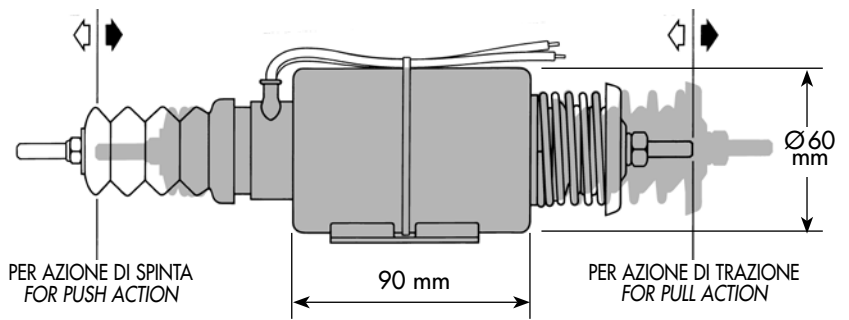
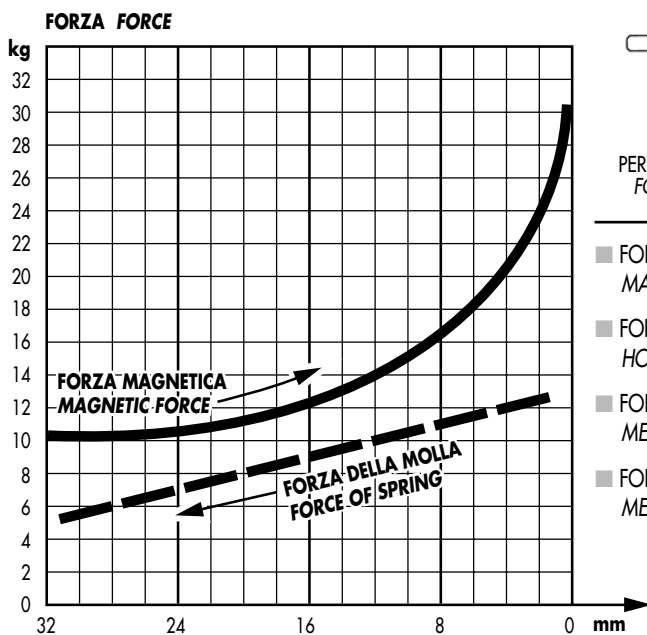
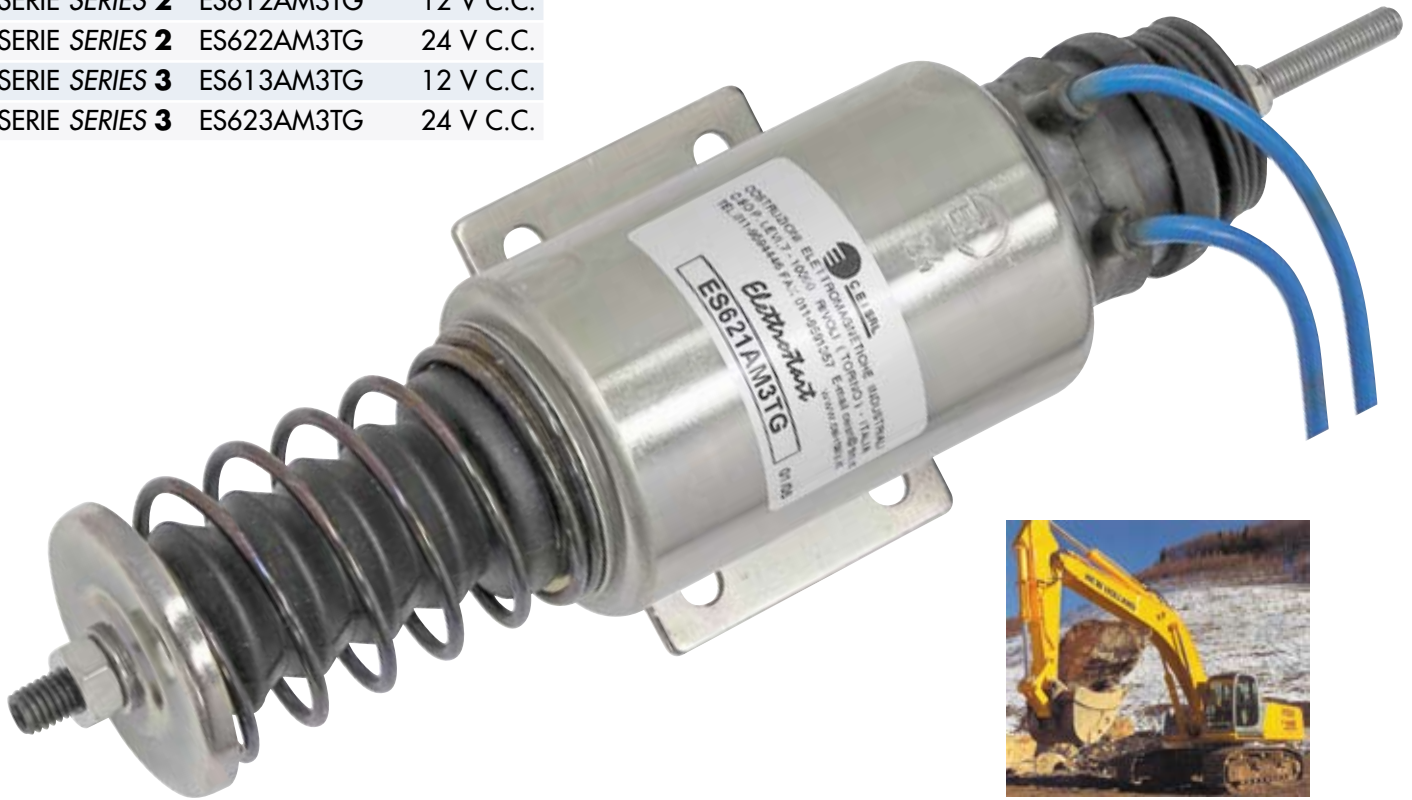

- FORZA MAGNETICA A INIZIO CORSA (32 mm) **Kg 10** BOBINA DI POTENZA  
MAGNETIC FORCE AT START OF STROKE (32 mm) **Kg 10** PULL COIL
- FORZA MAGNETICA DI MANTENIMENTO A CONTATTO (A FINE CORSA) **Kg 25** BOBINA DI MANTENIMENTO  
HOLDING MAGNETIC FORCE ON DIRECT CONTACT (AT END OF STROKE) **Kg 25** HOLD COIL
- FORZA MECCANICA DELLA MOLLA A INIZIO CORSA **Kg 5**  
MECHANICAL FORCE OF THE SPRING AT START OF STROKE **Kg 5**
- FORZA MECCANICA DELLA MOLLA IN COMPRESSIONE **Kg 12**  
MECHANICAL FORCE OF THE SPRING IN COMPRESSION **Kg 12**

ESEMPIO DI CORSA DI 32 mm IN TRAZIONE O SPINTA  
EXAMPLE OF STROKE OF 32 mm FOR PULL OR PUSH